

*Introducing...*

**FLUSHMATE® IV**  
For High Efficiency™ Toilets

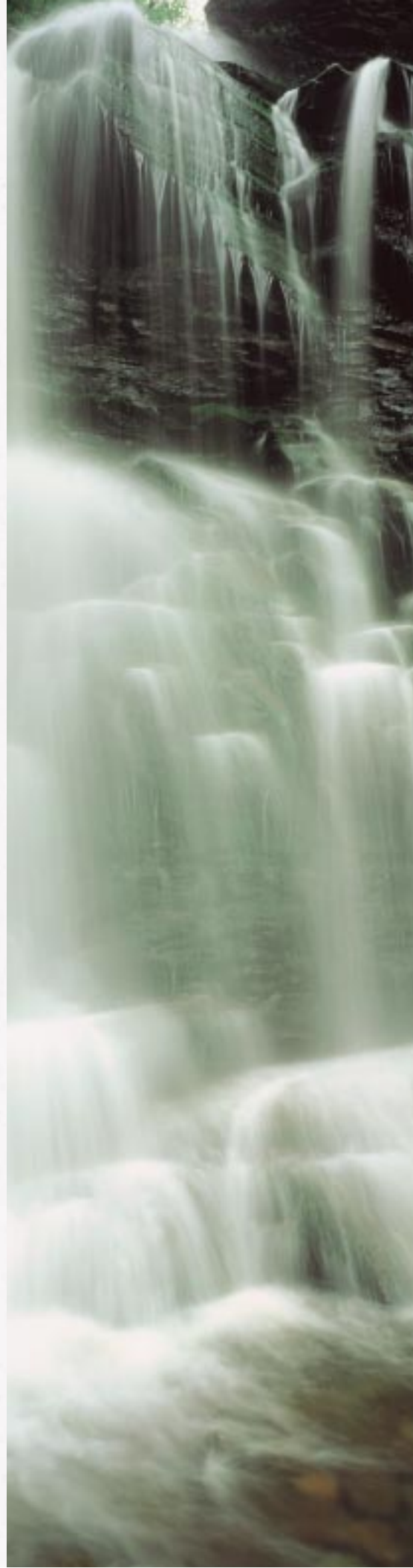

**FLUSHMATE®** Pressure Assist 1.0 Gallon/3.8 Liter Operating System



# Introducing **FLUSHMATE**

## Superior Performance

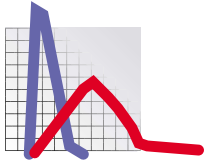

The peak flow of pressure-assist technology is more than double that of gravity-type fixtures at 70 gallons per minute. It's a remarkable, simple and effective design that has made *FLUSHMATE*® the performance leader in pressure-assist flushing.

## Advanced Bowl Design

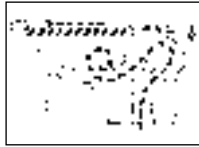

Since a pressure-assist bowl does not require a siphon to extract waste, the trap dimension is the same throughout. This allows for the easy removal of waste throughout the trapway. In combination with a specifically designed jet at the entrance of the trapway, *FLUSHMATE*-equipped toilets rapidly push the waste out of the bowl.

## Largest Water Surface Area



*FLUSHMATE*-equipped toilets stay cleaner due to a large water surface area and vigorous flushing action.

## Non-Sweating Tank



Water is contained in the *FLUSHMATE* vessel. The result is a non-sweating toilet – so the floor around the toilet remains dry. The additional cost of an insuliner tank is not necessary.

## Conventional Installation



Installs in the same standard dimensional area as a conventional water closet, with no special tools. A minimum of 25 pounds-per-square-inch (172.5 kPa) water pressure is required.

*FLUSHMATE* 1.0 gallon/3.8 liter toilets are available in 12" rough-in, in all popular styles and colors.

Fewer moving parts, so there's less chance for things to go wrong.

## Water Conservation



*FLUSHMATE*® IV flushes less than 4 liters per flush, and does not leak. Compared to other systems, *FLUSHMATE* IV saves 40 to 70% more water.

## How Much Water Does Your Toilet Use?

If your toilet flushes 3.4 gallons/13 liters per flush, one person can consume as much as 19.5 gallons/74 liters\* per day, or 7135.2 gallons/27,010 liters per year.

If your toilet flushes 1.6 gallons/6 liters per flush, one person can consume as much as 10.5 gallons/39 liters\* per day, or 3760.2 gallons/14,234 liters per year.

If your toilet is equipped with *FLUSHMATE* IV, one person can consume as little as 5.3 gallons/20 liters per day, or 1928.5 gallons/7,300 liters per year.

\*Includes toilet leakage

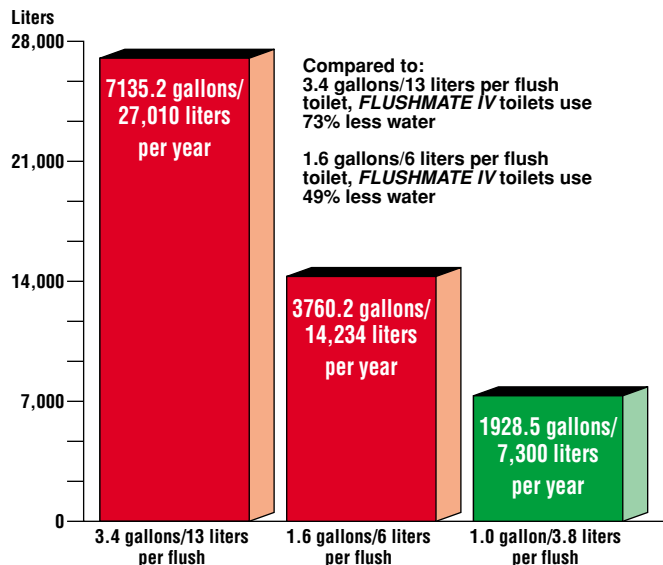

*FLUSHMATE* pressure-assist technology has been successfully used for more than 20 years. With millions of Flushmates installed, *FLUSHMATE* has a proven track record for water saving, reliability, and reduced maintenance.

Sloan *FLUSHMATE* offers a ten (10) year warranty on the replacement components and a lifetime limited warranty on the *FLUSHMATE* vessel.

# FLUSHMATE® IV

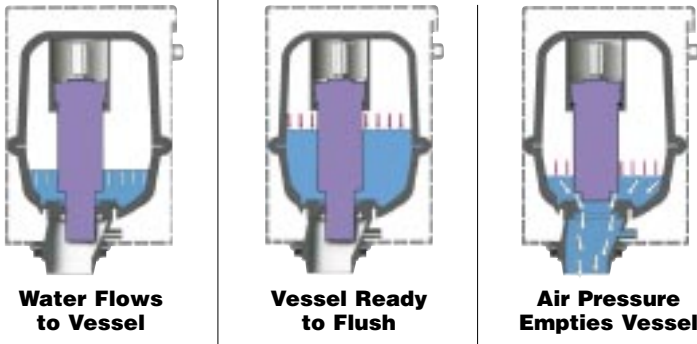

## How It Works

The *FLUSHMATE* vessel traps air, and as it fills with water, it uses the water supply line pressure to compress the trapped air inside. The compressed air is what forces the water into the bowl. So instead of the "pulling" or siphon action of a gravity toilet, the pressure-assist toilet "pushes" waste out. This vigorous flushing action cleans the bowl better than gravity units.

## FLUSHMATE® IV is Quieter

The bowl design is primarily responsible for the sound produced in a toilet flushing. *FLUSHMATE* engineers can measure any phase of the flush cycle and examine the sound in a multitude of ways using advanced software and their acoustical full reverberation chamber. Toilets from around the world are tested, producing information to help manufacturers improve bowl design.

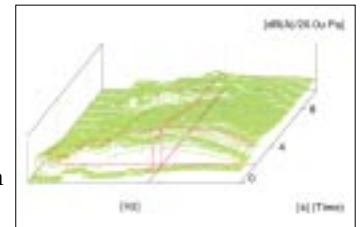

Based on sound test evaluations, the sound of *FLUSHMATE IV* equipped toilets is virtually identical to low consumption gravity toilets.

### EXTRACTION PERFORMANCE

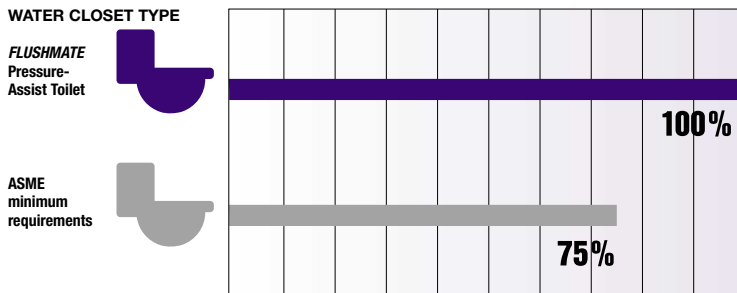

Based on ASME Standard A112.19.6 Hydraulic Performance Requirement

## FLUSHMATE IV Liter Components List

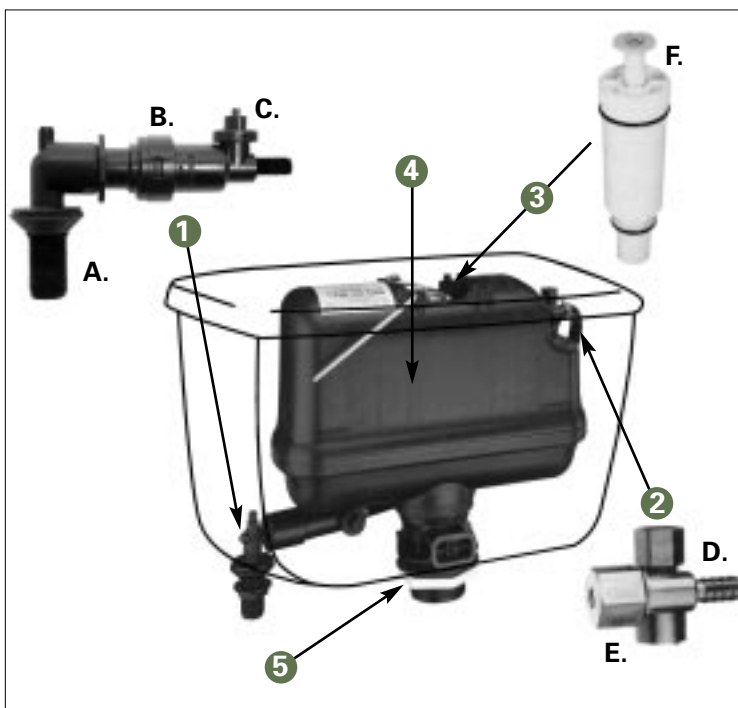

### 1. Lower Supply Group with Hose

- A. Supply Shank with Screen
- B. Pressure regulator with Back Check (preset at 35 psi)
- C. Relief Valve (preset at 60 psi)

### 2. Upper Supply Group

- D. Air Inducer
- E. Vacuum Breaker

### 3. Flush Valve Cartridge Assembly

- F. Actuator with setscrew

### 4. Vessel

### 5. Discharge Extension with Drain

### Installation Requirement

Minimum line pressure range of 25 psi to 125 psi. *FLUSHMATE* is an integral part of a complete toilet and is not designed to be used on gravity-type toilets.

### Warranty:

All *FLUSHMATE* units carry a ten (10) year limited warranty.



# The Choice is Clear: *FLUSHMATE*® for Performance and True Water Conservation

Toilets with *FLUSHMATE* inside offer the public the best opportunity to achieve maximum water conservation without sacrificing performance. Sloan *FLUSHMATE* supplies *FLUSHMATE* pressure-assist systems to leading fixture manufacturers in the United States. Fixtures with *FLUSHMATE* are offered in a variety of styles and color.

- In public housing — *FLUSHMATE* toilets were preferred by professional builders in a nationwide survey because of their performance characteristics. More consumers own *FLUSHMATE*-equipped toilets than any other pressure-assist system.
- In residential, multi-housing — *FLUSHMATE* ensures savings for the life of the fixture as well as the integrity of the plumbing system. It offers owners the best opportunity to save water – without compromising performance.
- In hotels — *FLUSHMATE* provides guests with performance and reduces maintenance costs to hotel owners. Besides saving water and offering maximum performance, *FLUSHMATE*-equipped toilets require less maintenance and housekeeping.

In application after application, *FLUSHMATE* proves to be the leading conservation choice in technology and toilet design.

Now, with our 1.0 Gallon/3.8 Liter Operating System, we can save more water than ever before.

*FLUSHMATE*'s 1.0 Gallon/3.8 Liter Operating System provides a way to conserve water while using only 1.0 Gallon/3.8 Liters of water or less. This operating system and toilet design deliver true performance without compromise. *FLUSHMATE* offers durability, reliability and performance.



**FLUSHMATE**®  
A Division of Sloan Valve Company

10500 Seymour Avenue • Franklin Park, IL 60131  
Phone: 800-875-9116 • Fax: 847-671-4611  
www.flushmate.com

